

# Control® 28-1

Professional Series – High-Output Indoor/Outdoor Background/Foreground Speaker



## Key Features:

- Components:
  - 8" woofer with woven fiberglass cone
  - 1" PEI diaphragm tweeter with fluid cooling
- Contemporary, high-design appearance
- Built-in InvisiBall® mounting hardware, plus available U-bracket
- Weather resistant enclosure and transducers
- Wide 100° x 100° coverage
- 120W power handling (240W program) in direct 8Ω setting, plus built-in 60W 70V/100V multi-tap transformer
- High fidelity sound character with broad frequency response of 45 Hz – 20 kHz



## Description:

The Control 28-1 is a two-way 8" speaker with rich sonic character, wide coverage, consistent coverage, versatile mounting, and a contemporary high-design look that fits into a wide range of decors. This makes Control 28-1 an excellent choice for a wide variety of applications, including retail stores, restaurants, health clubs, theme parks, educational facilities, hospitality, music cafes, leisure venues, and anywhere where a top quality high-output indoor/ outdoor foreground/background music (and/or paging) speaker is required.

The unique InvisiBall mounting hardware is included in with each system, making short work of permanent installation. The InvisiBall mounting method provides a high degree of both vertical and horizontal rotation, and because InvisiBall adjustments are made through a hidden access behind the logo badge, the grille never needs to be removed and there exists a high degree of theft deterrence as well. Integrated M6 mounting points for an optional U-bracket adds to the installation versatility.

The LF driver's woven fiberglass cone provides durability and weather capable performance. The light weight high temperature fiberglass voice coil former and high temperature voice coil wire ensures stable performance under longterm high-power working conditions while also providing high sensitivity and high power capability. The pure butyl rubber surround delivers clean sound and ruggedness, while terminating its circumference in JBL's WeatherEdge™, a seamless, rubberized extension of the woofer surround that provides added protection to critical transducer elements. Cone geometry is optimized for smooth frequency response and good off-axis performance, while an FEA-optimized motor construction and linear suspension spider helps to lower harmonic distortion.

The HF driver's low viscosity ferro-magnetic fluid increases voice coil cooling for higher long-term power handling. The PEI diaphragm delivers a smooth high frequency sound quality. A light weight Kapton™ voice coil former increases durability while providing better high frequency response extension. All these factors also contribute toward making the driver especially rugged for outdoor and other stressful applications.

In addition to the driver designs contributing toward a high degree of weather resistance, the cabinet provides excellent endurance against sun, salt and moisture. Grilles are heavily zinc-plated and finished in a tough, high-grade powder coating for rust resistance, and optional MTC-28WMG-1 WeatherMax™ grilles are available for especially difficult environments and to break up driving rain. Connection is made via weather-capable screw-down terminals, and the optional MTC-PC2 and MTC-PC3 panel covers are available to protect the terminal compartment, providing a water-tight sealed gland-nut entrance (when used with round-jacketed cable within the specified diameter range).

The frequency response is extremely smooth, resulting in a very natural sound character, and the response extends down to 45 Hz, providing strong bass capability. The system is capable of handling 120 watts continuous pink noise (240 watts program) at its 8 ohm setting and is also equipped with a built-in 60W 70V/100V multi-tap transformer for operation on distributed speaker lines. The combination of high sensitivity and power handling provides high Max SPL of 112 dB.

The Control 28-1 readily accepts a variety of paints and finishes to match any décor. Available in black or white (-WH).

# Control® 28-1

Professional Series – High-Output Indoor/Outdoor Background/Foreground Speaker



## Specifications:

<b>System</b>	
Frequency Range (-10 dB) <sup>1</sup>	45 Hz – 20 kHz
Frequency Response (±3 dB)	62 Hz – 16 kHz
Power Rating <sup>2</sup>	240W Continuous Program (2 hrs) 120W (480W peak), Continuous Pink Noise (2 hrs) 90W (360W peak) Continuous Pink Noise (100 hrs)
Maximum Input Voltage	27.5 V RMS (2 hrs), 55.0 V peak
Maximum SPL <sup>3</sup>	112 dB ave. Continuous Pink Noise (118 dB peak)
Sensitivity <sup>4</sup>	91 dB, 1W/1m (ave. 100 Hz – 10 kHz)
Coverage Angle <sup>5</sup>	100° x 100°
Directivity Factor (Q)	7.3 (averaged 1kHz – 16kHz)
Directivity Index (DI)	8.3dB (averaged 1kHz – 16kHz)
Nominal Impedance	8 ohms (THRU setting)
Crossover Type	2nd order low-pass, 1st order high-pass, plus conjugate shaping
<b>Circuitry</b>	
Transformer Taps	70V: 60W, 30W, 15W, 7.5W 100V: 60W, 30W, 15W Insertion Loss: <0.94 dB at any tap setting Thru Setting: 8Ω nominal
Recommended Protective High-Pass <sup>6</sup>	45 Hz high-pass (24 dB/oct) for 8Ω operation plus 15W and 7.5W taps; 55 Hz for 30W tap; 65 Hz for 60W tap
<b>Transducers</b>	
Low Frequency	200 mm (8 in), woven-fiberglass cone with pure butyl rubber surround with Weather-Edge frame protection, high-temp fiberglass voice coil former, high-temp voice coil wire, optimized cone geometry, linear suspension spider, and FEA optimized motor structure
High Frequency	25 mm (1 in) PEI diaphragm, low-viscosity ferro-magnetic fluid, and lightweight Kapton™ voice coil former
<b>Physical</b>	
Enclosure Material	High Impact Polystyrene (HIPS) with 10% glass fill, painted with highly-UV resistant paint on white (-WH) version for maximum UV fade resistance
Grille	Highly zinc-plated, finished in durable TGIC polyester powder coating. MTC-28WMG-1 (&-WH) available with Weather-Max™ multi-layer foam and tight-weave mesh vapor barrier backing.
Installation	InvisiBall wall-mounting system included. Two 6 mm attachment points (on top and bottom) for optional MTC-28UB-1 (&-WH) U-bracket. Secondary safety attachment loop point on back panel.
Environmental	IP-44 per IEC529 (IP-55 when installed with the optional MTC-28WMG-1 WeatherMax™ grille and either MTC-PC2 or MTC-PC3 panel cover.) Exceeds MilSpec 810 for humidity, salt-spray, temperature & UV. Passes MilStd-202F for salt spray and ASTM G85 for acid-air plus salt spray. Optional MTC-28WMG-1 WeatherMax™ grille for breaking up driving rain and for especially difficult environments.
Termination	Screw-down terminal strip, zinc-plated copper based, nickel-plated metal screws and washers. Accepts up to 9 mm outside 4 mm inside open lugs (#6, #8, or #10 lug), plus bare wire (up to 12 AWG / 2.5 mm <sup>2</sup> ). Optional MTC-PC2 and MTC-PC3 protective panel covers available to provide sealed entrance for additional weather protection.
Agency Rating	ROHS-compliant; Transformer UL Recognized per UL1876
Colors	Black (RAL9004) or white (-WH, RAL9016)
Dimensions (H x W x D) <sup>7</sup>	386 x 282 x 219 mm (15.2 x 11.1 x 8.6 in); 277 mm (10.9 in) deep total when mounted on InvisiBall wall-mount bracket
Net Weight	6.8 kg (15.0 lbs)
Shipping Weight	15.4 kg (34 lbs) pair-packed (for 2 speakers)
Included Accessories	» InvisiBall™ wall-mounting system), 6 mm x 180 mm hex key
Optional Accessories	» MTC-28UB-1 – Yolk-type U-bracket (&-WH) » MTC-28WMG-1 – WeatherMax grille with backing (&-WH) » MTC-28/25CM – Ceiling-Mount InvisiBall adapter (&-WH)

<sup>1</sup> In half-space (on-wall, 2pi)

<sup>2</sup> At 8Ω setting. Continuous Pink Noise rating is IEC-shaped pink noise with a 6 dB crest factor. Continuous Program Power is defined as 3 dB above the Continuous Pink Noise Rating and is a conservative expression of the system's ability to handle normal speech and music program material.

<sup>3</sup> Calculated from sensitivity and power handling, exclusive of power compression, at THRU setting

<sup>4</sup> Half-space (on-wall) averaged 100 Hz – 10 kHz, 2.83V

<sup>5</sup> Coverage angle (-6 dB) average between 600 Hz and 12 kHz

<sup>6</sup> For protection against driving below resonant frequency and to keep transformer out of saturation

<sup>7</sup> In vertical orientation

JBL continually engages in research related to product improvement. Changes introduced into existing products without notice are an expression of that philosophy.

# Control® 28-1

Professional Series – High-Output Indoor/Outdoor Background/Foreground Speaker



## Mounting Dimensions:

Dimensions in mm (inches)

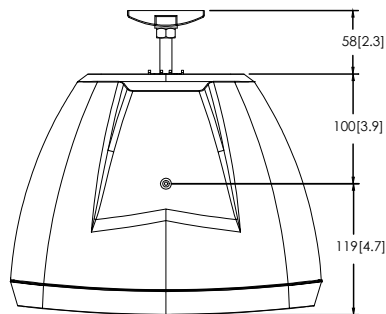
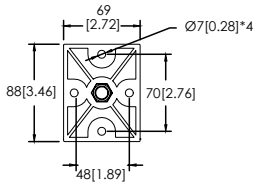
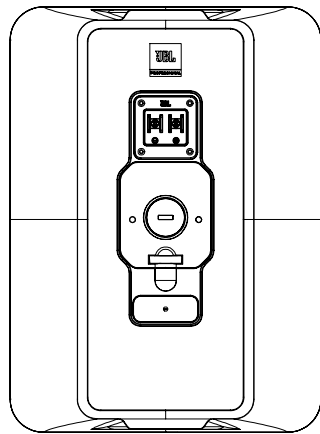
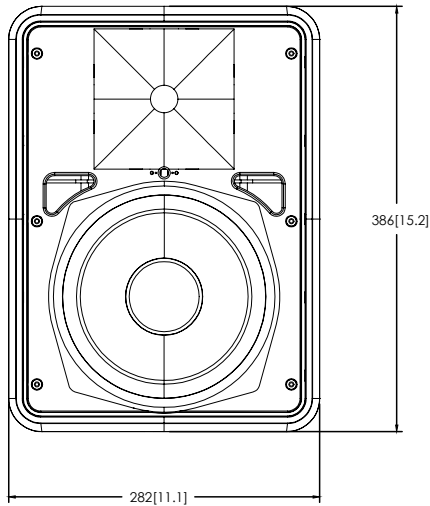

C/L

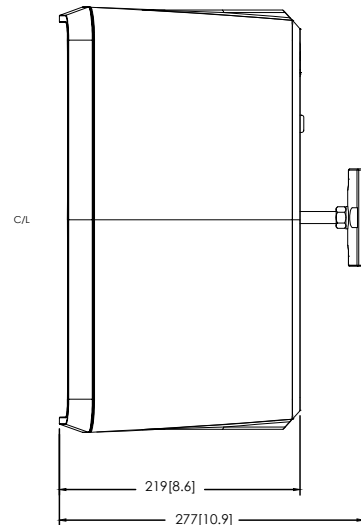

## Frequency Response:

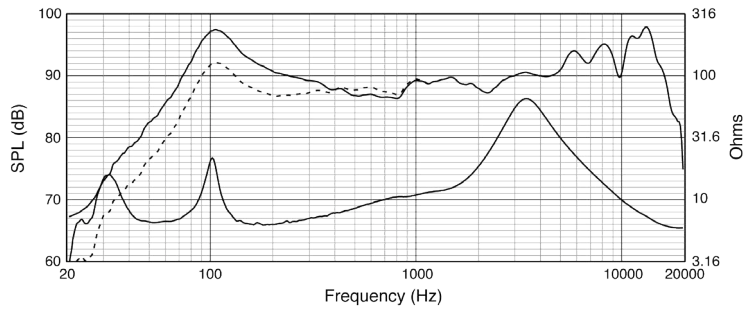

On-axis in half-space (2pi, solid line) and full-space (4pi, dotted line) at thru (8Ω) setting; input impedance (lower solid line)

## Beamwidth vs. Frequency:

